

=25°C (unless otherwise specified)

		=25°C		
		=100°C		
		=25°C		
			±	
		=25°C		
		=25°C		
				°C

			°C/W
			°C/W

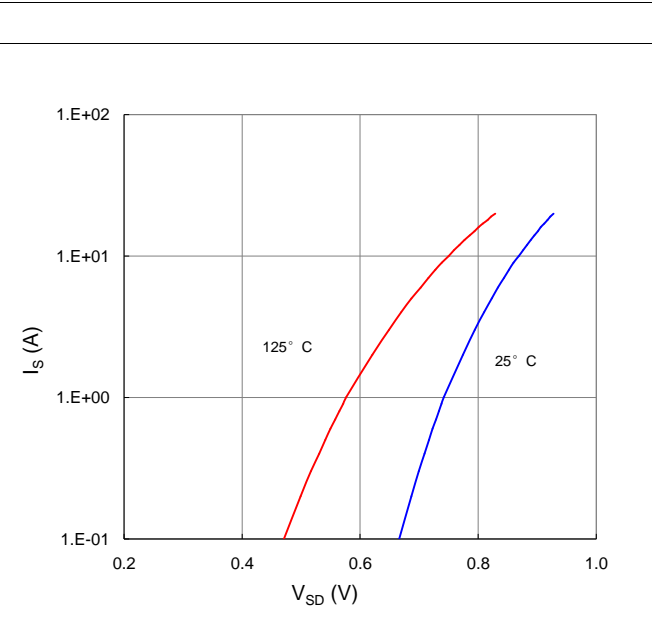

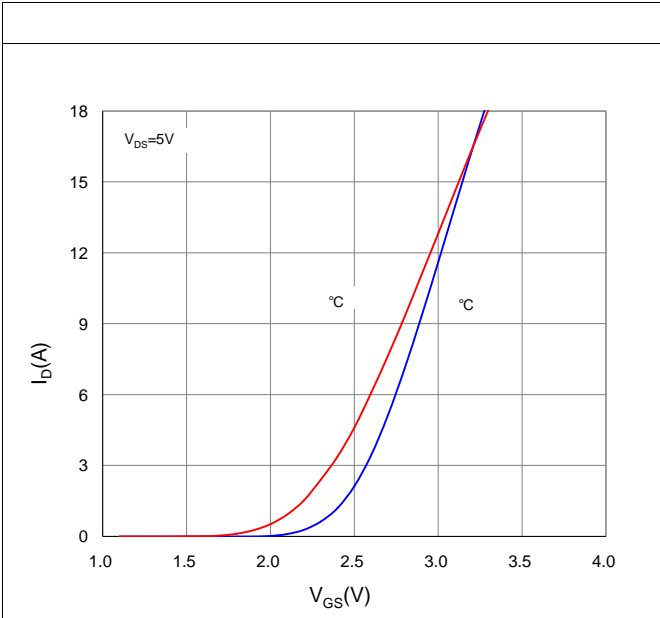
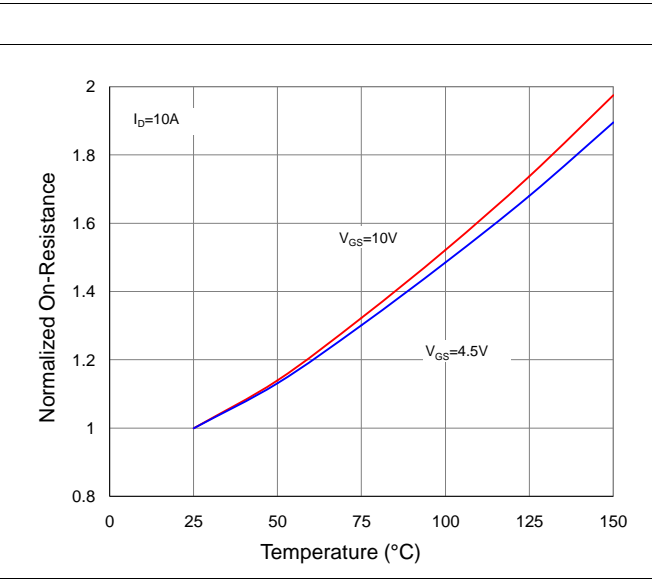
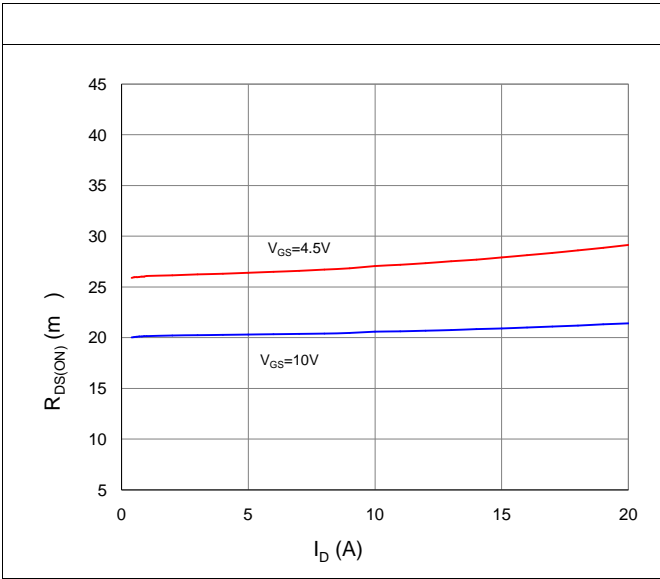
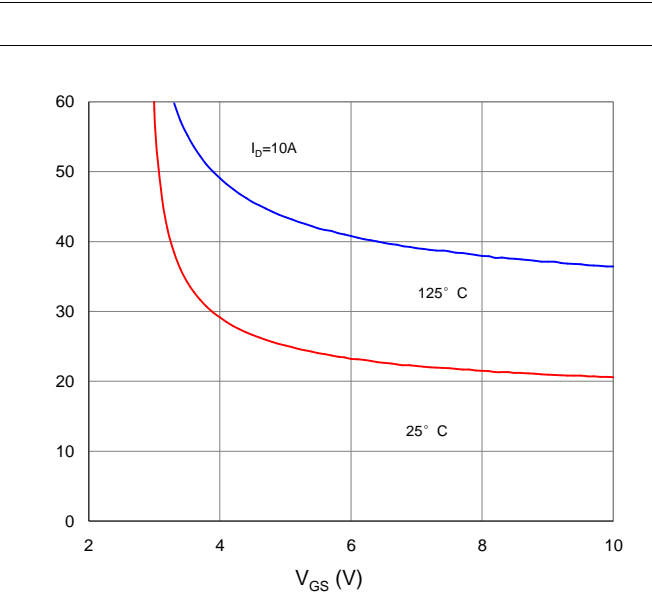
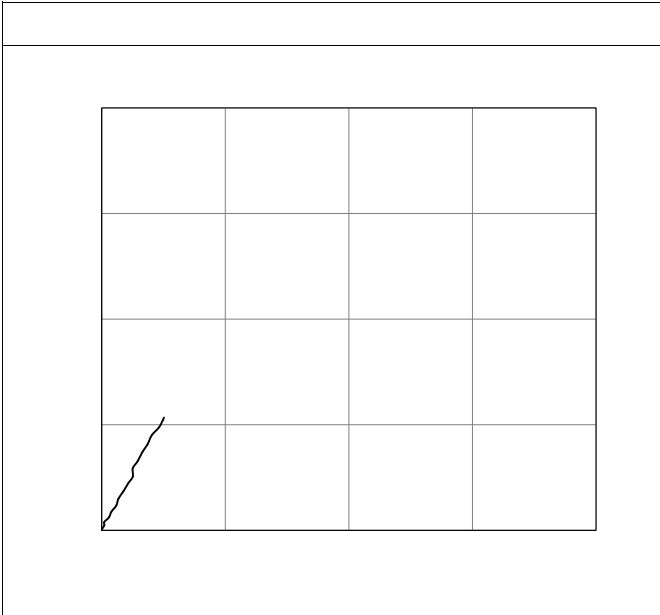

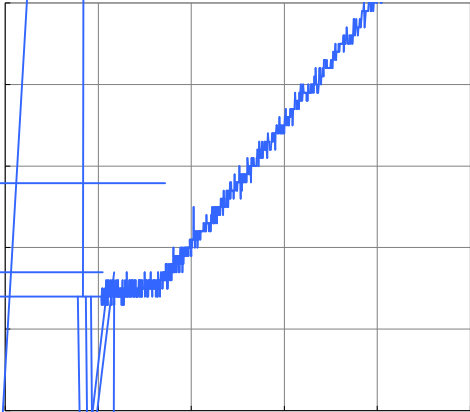

--	--

--	--

--	--

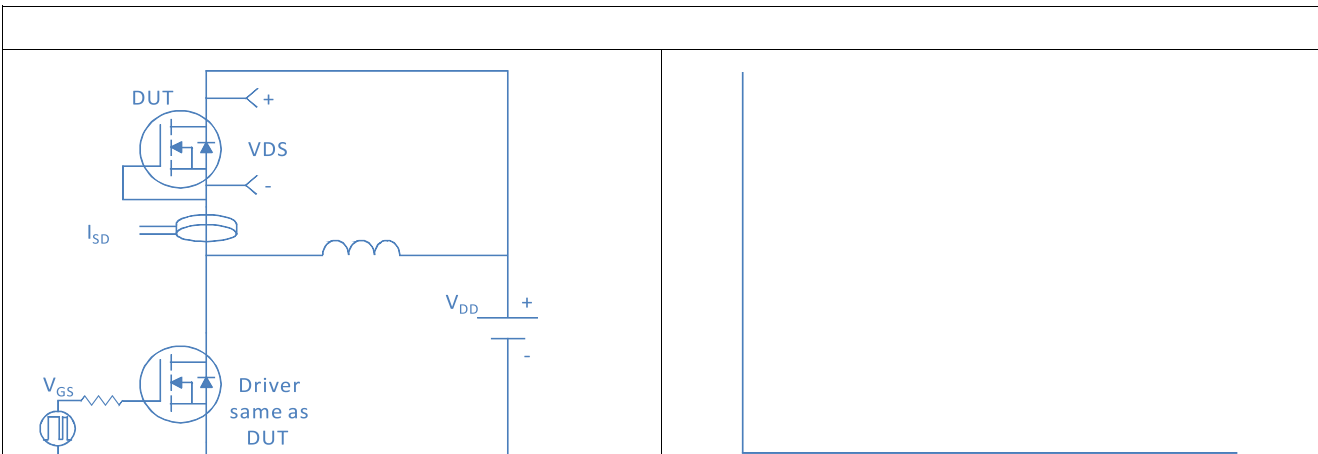
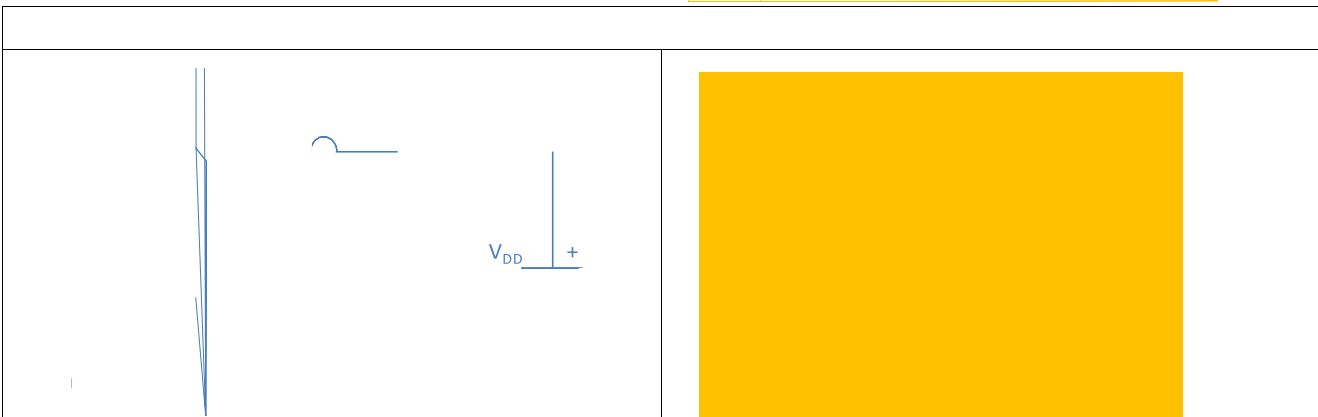
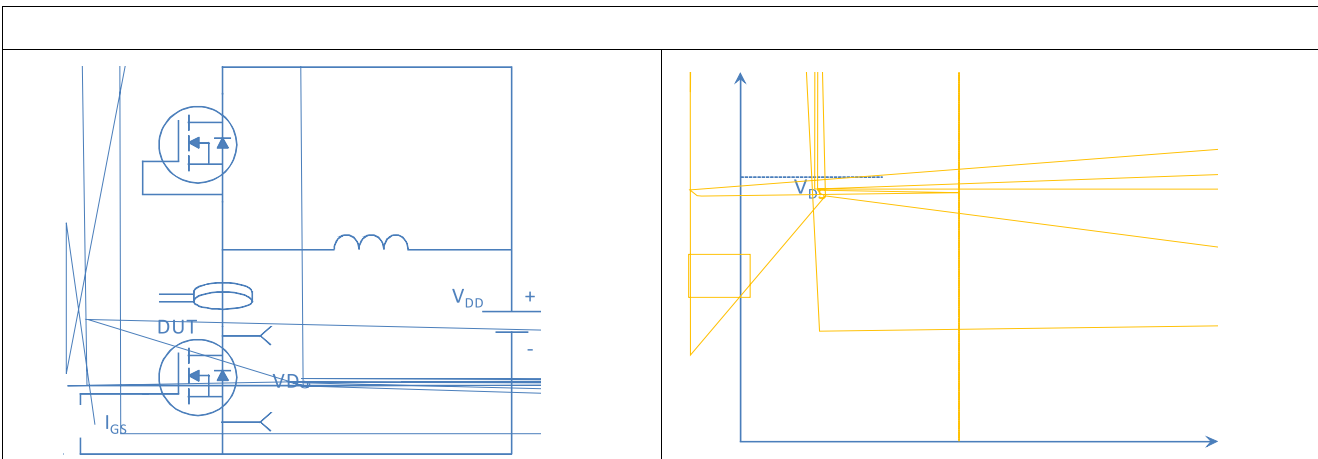
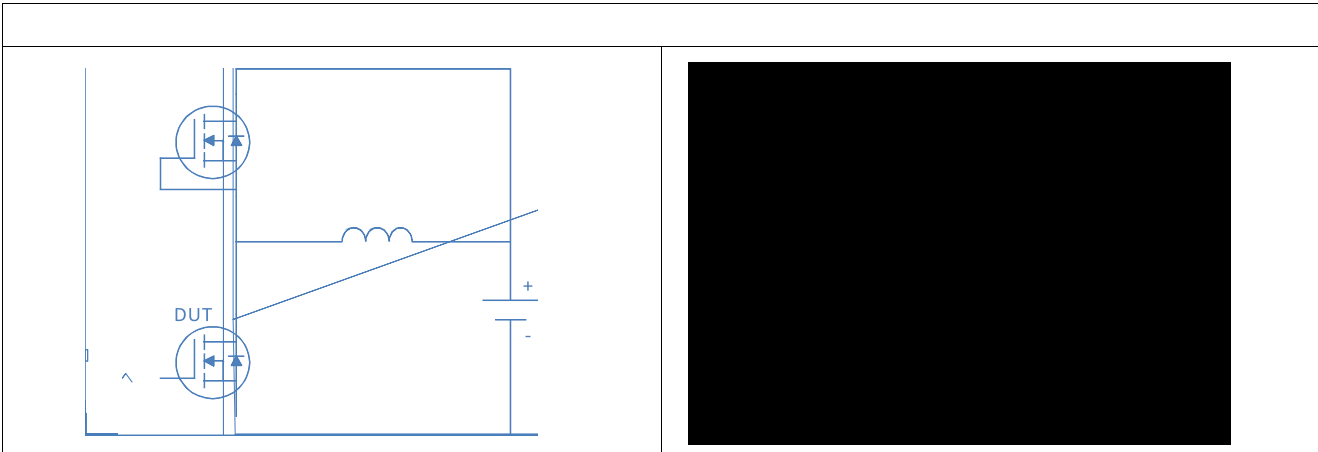

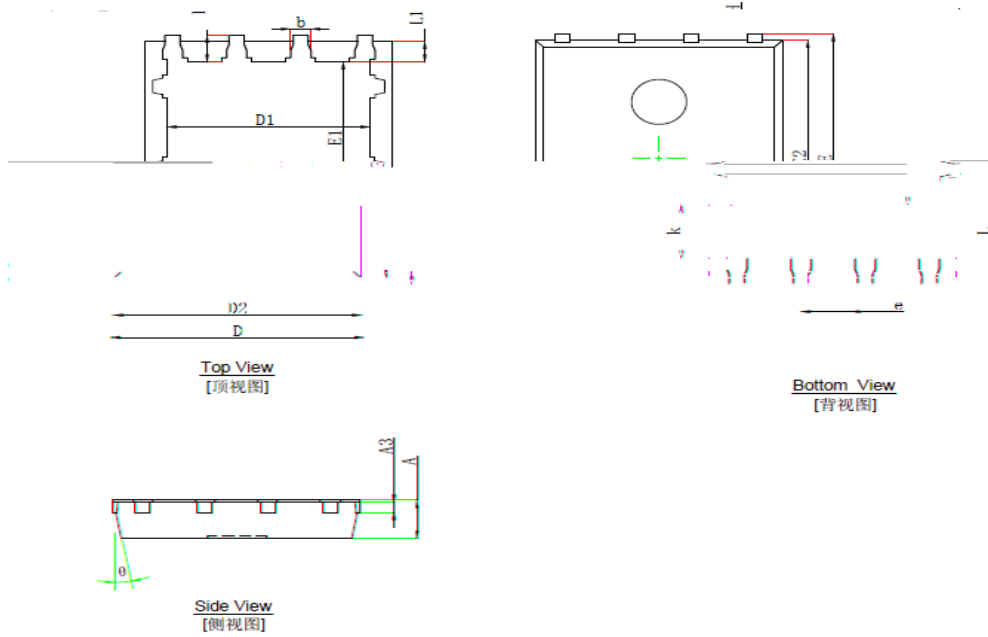

Symbol	Dimensions In Millimeters			Dimensions In Inches	
0.035	0.047	0.057	A	0.500	1.100
0.154	0.200	0.241	B	4.500	5.100
0.200	0.241	0.281	C	5.000	5.175
0.140	0.180	0.220	D	3.510	4.110
0.120	0.135	0.150	E	3.300	3.750
0.155	0.187	0.219	F	4.500	5.000
0.220	0.252	0.284	G	5.571	5.500
0.040	0.050	0.060	H	1.100	1.200
0.010	0.020	0.030	I	0.250	0.510
	1.270 INP		J	1.270 INP	
0.020	0.025	0.030	K	0.510	0.711
0.017	0.020	0.023	L	0.434	0.570
0.015	0.020	0.025	M	0.410	0.720
"	"	"	N	"	"